

ChargePoint Gateway Installation Instructions

You must be a licensed electrician and complete online training (<http://chargepointuniversity.netexam.com/>) to become a ChargePoint Certified Installer, and to get a login for ChargePoint. If you do not complete this training, you will be unable to complete the installation process.

A ChargePoint Gateway consists of a cellular Gobi modem for wide area networking and built-in WiFi for local communications to and from CPF25 charging stations. The ChargePoint Gateway must be located where cellular signals are optimum for either 3G Verizon or 3G AT&T service, and each ChargePoint Gateway must be located within 150 feet line-of-sight to the CPF25 charging stations. Each CPF25 charging station has built-in WiFi capability to communicate with the ChargePoint Gateway to access ChargePoint network services.

The ChargePoint Gateway is a UL Class 2 device and requires less than 4W power (less than 0.4 Amps using single-phase 110/120V, or less than 0.2 Amps using single-phase 208V service). ChargePoint recommends hard-wiring the ChargePoint Gateway with electrical termination to the power source. However, you can install the ChargePoint Gateway in close proximity to a CPF25 charging station, in an area where cellular signal levels are acceptable. Then tap into L1 and L2 of the 208/240V electrical circuit at the junction box used for the Level 2 charging station and install flexible conduit from the junction box to the wall-mounted ChargePoint Gateway to run electrical wiring (use L1 and L2 only – not ground wire). The ChargePoint Gateway must be located approximately 2 to 4 feet from the CPF 25 charging station and 6 to 8 feet above floor level. The ChargePoint Gateway must be within 150 feet line-of-site to as many as nine CPF25 stations. Note that the WiFi signal strength between the ChargePoint Gateway and the charging stations will be strong, and signals will bend (diffract) around narrow columns with low signal loss. Avoid installations where concrete walls are located between the ChargePoint Gateway and the CPF25 charging stations.

For detailed specifications, refer to the ChargePoint Gateway data sheet located at www.chargepoint.com.

Before You Begin

Before installing the ChargePoint Gateway, choose an appropriate location by considering the following:

- Does the location receive consistently available 3G EVDO (Verizon) or WCDMA (AT&T, Rogers) cellular coverage? The signal strength should be better than -90db (for example, -85db is better than -90db). To ensure adequate signal strength in underground garages or other enclosed parking structures, cellular repeaters may be required.

NOTE: For maximum cellular coverage, mount the ChargePoint Gateway as high as possible.

- Are all charging stations located within 150' line-of-sight?
- Is power available at the installation site?

It is recommended that you permanently install the ChargePoint Gateway (see page 3) by running service wiring into the bottom of the gateway through 1/2" conduit and attaching it to a wall using the supplied screws and wall anchors. The ChargePoint Gateway can also be temporarily mounted and plugged into a 120 VAC wall outlet (see page 4). A temporary installation is intended only to verify adequate cellular coverage before permanently installing it at a proposed location.

Contents of the Shipping Box

- Main unit with cover (1)
- 1/4" drill bit (1)
- #10 x 1" screws (5)
- Wall anchors (5)
- Installation template (1) - inserted in the center of this installation guide (1)
- Spare activation label (1) - a duplicate label is attached to the inside of the main unit

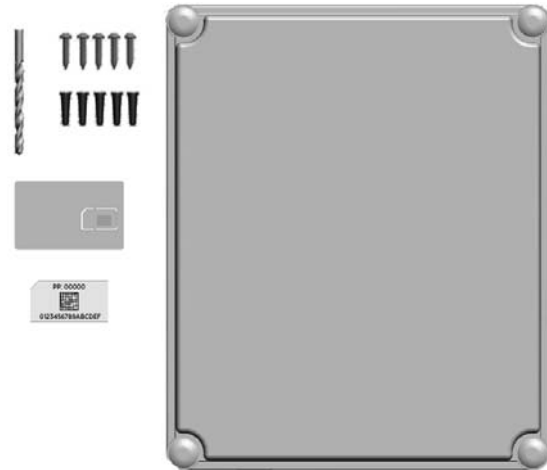

IMPORTANT: Keep the spare activation label. It contains critical information that you need to pinpoint the gateway, which prepares it for activation on ChargePoint (page 6).

You Will Need

- Drill
- Phillips screwdriver
- Two adjustable wrenches to remove the power plug when permanently hard-wiring

Overview of Steps

1. Install the ChargePoint Gateway. To install a permanent location, see page 3. To install at a temporary location, see page 4.
2. Install the Cover (see page 5)
3. Power On (see page 5).
4. Pinpoint the ChargePoint Gateway (see page 6)
5. Document the Radio Group (see page 7)
6. Complete the Post Installation Checklist (see page 8).

Permanently Install the Gateway

Follow the steps below to install the ChargePoint Gateway at a permanent location. The ChargePoint Gateway can also be temporarily mounted and plugged into a 120 VAC wall outlet (see page 4). A temporary installation is intended only to verify adequate cellular coverage before permanently installing it at a proposed location.

Mount the Main Unit

- Use the installation template to mark the location of the four mounting holes.
- Drill the four mounting holes and insert the anchors.
- Loosen the screws on the front of the ChargePoint Gateway to remove the front cover.
- Align the main unit with the mounting holes and fasten using four of the supplied #10 x 1" screws and a Phillips screwdriver.

Remove the Wall Plug

- Disconnect the wall plug's wiring from the terminal block.
- Using two wrenches, one on the inside and the other on the outside, remove the internal plastic nut.
- Remove the power cord from the ChargePoint Gateway.

Connect the Service Wiring

- Using 1/2" conduit and the appropriate fittings, route the appropriate length of 10-14 AWG stranded or solid service wiring to the ChargePoint Gateway and through the hole in the bottom (where you removed the power cord).
- Strip service wires 1/4".
- Connect L1 and L2 (or L and N) service wiring, as shown.

NOTE: AC inputs are universal and support from 100-240 VAC.

To avoid running a separate electrical circuit, you can connect the ChargePoint Gateway to an existing 208V/40A electrical circuit by tapping into the L1 and L2 wiring (not ground) of an installed CPF25 charging station. The ChargePoint Gateway must be located within approximately two to four feet of the CPF25. Use flexible conduit to run wiring from the junction box to the ChargePoint Gateway.

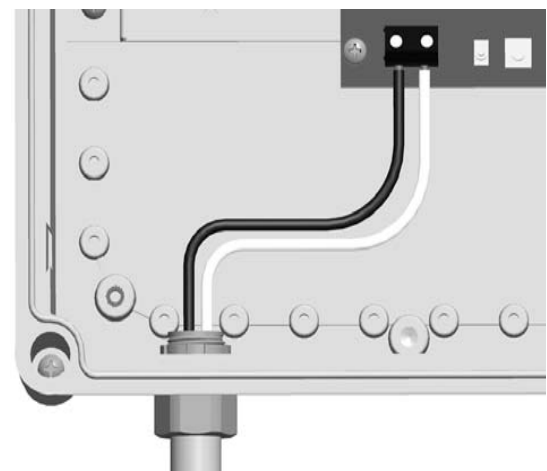
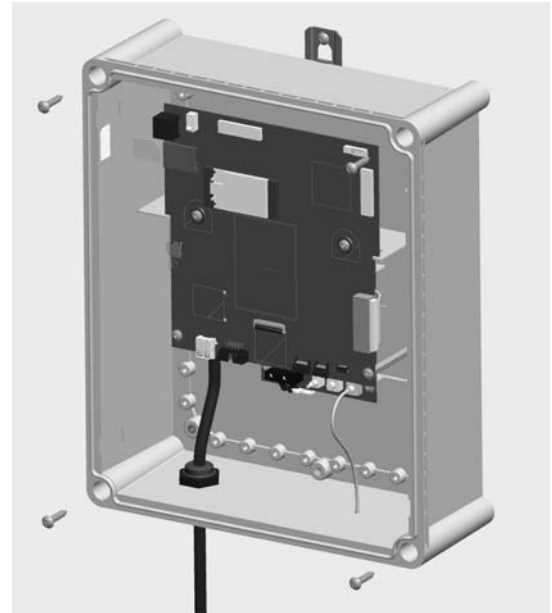

Temporarily Install the Gateway

This method is designed for temporary use only. It is recommended that you permanently install the ChargePoint Gateway by following the steps on the previous page. Temporary installations are intended only as a quick way to power up the gateway by plugging it into a wall outlet. This can help confirm that the installation location has an adequate cellular signal and that all associated charging stations are within range. Once this is determined, you must permanently install the ChargePoint Gateway.

- Use the installation template to mark the location of the top center mounting hole for a single screw.

NOTE: The unit must be mounted within 48" of the outlet.

- Drill the mounting hole and insert an anchor.
- Drive one #10 x 1" screw into the mounting hole, leaving 1/8" protruding.
- Loosen the screws on the front of the ChargePoint Gateway to remove the front cover.
- Hang the ChargePoint Gateway on the protruding screw, as shown.



Install the Cover

Align the cover to the front of the main unit and turn the screws to lock the cover into place.



Power On

Power on the ChargePoint Gateway by switching the service breaker ON (or for temporary installations, by plugging it into the power outlet).

As the ChargePoint Gateway powers up, the LED flashes yellow as it attempts to communicate with the cellular network. When cellular communications is established, the LED is solid yellow.

If the Gateway continues to flash yellow for an extended period, check the strength of the cellular signal at the installation location. You may need to strength the signal by installing cellular repeaters.



Pinpoint the ChargePoint Gateway

After completing the physical installation of the ChargePoint Gateway, you must prepare it for activation on the ChargePoint network by pinpointing its exact location.

You will need:

- The ChargePoint Gateway's MAC address and activation password (this information is printed on an activation label that is affixed to the main unit and a spare label is included in the shipping box).
- The exact location where the ChargePoint Gateway is physically installed.
- A smart phone with Internet access.
- Installer account information (user name and password) on ChargePoint (provided upon completion of training).

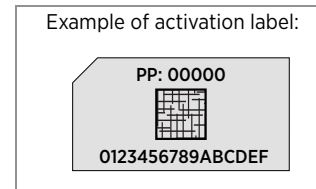

Follow these steps:

1. Using your smart phone, navigate to the ChargePoint mobile site: <https://m.chargepoint.com>.
2. Log in using your installer credentials.
3. Enter the MAC address and activation password (described above).
4. When prompted, touch OK to share your GPS location data with the ChargePoint mobile site.
5. When prompted, touch OK to review the gateway's location on Google™ Maps.
6. Review the address and zoom in to check the location of the gateway's pin on the map.
7. Using your finger, move the pin to the most accurate location possible.
8. If needed, manually adjust the address of the gateway's location.
9. Take a photo of the gateway using your smart phone, scroll down to "Upload a Station Picture", then choose the photo.
10. Touch SUBMIT to pinpoint the gateway on the ChargePoint map.



Document the Radio Group

A radio group consists of a ChargePoint Gateway and up to nine CPF25 charging stations that it communicate with over WiFi. For each radio group, attach the spare activation labels below to document how stations are organized. After completing this step and the checklist on the following page, provide this information to the person responsible for activating the gateway and the CPF25 charging stations. If installing multiple radio groups, use one page for each radio group (this page is included in all Installation Guides).

Gateway	attach spare activation label here		
CPF25	attach spare activation label here	CPF25	attach spare activation label here
CPF25	attach spare activation label here	CPF25	attach spare activation label here
CPF25	attach spare activation label here	CPF25	attach spare activation label here
CPF25	attach spare activation label here	CPF25	attach spare activation label here
CPF25	attach spare activation label here	NOTE: Up to nine CPF25s can communicate with a ChargePoint Gateway.	

Complete the Post-Installation Checklist

Before leaving the installation site, complete this checklist for the ChargePoint Gateway. Then provide this information, along with the information on the previous page, to the person responsible for activating the ChargePoint Gateway.

Customer:

Name

Site Address

Contact

Installer:

Installer Name

Installer Contact Information

Company

Address

Phone

- Service wiring has been fully inserted into the terminal block and all electrical connections are clean and snug.
- The gateway is firmly mounted to a wall.
- The cover is locked in place and conduit is firmly attached.
- The LED located at the bottom of the ChargePoint Gateway is solid green (this can take up to 10 minutes).
- The area is clean and free of all packaging and debris.
- All pinpointing steps have been complete.
- You have documented the radio group (the ChargePoint Gateway and associated CPF25 charging stations) on the previous page.



ChargePoint, Inc.
254 East Hacienda Avenue
Campbell, CA 95008 USA
US toll free: +1-877-850-4562
www.chargepoint.com